

G66 PRO SERIES

Maximum Flow Rate: 236 l/min (62.5 USgpm) 2142 BPD
Maximum Pressure: 69 bar (1000 psi) for Metallic Pump Heads
17 bar (250 psi) for Non-metallic Pump Heads

 **WANNER™** HYDRA-CELL® PRO
SEAL-LESS PUMP TECHNOLOGIES

UK
CA CE

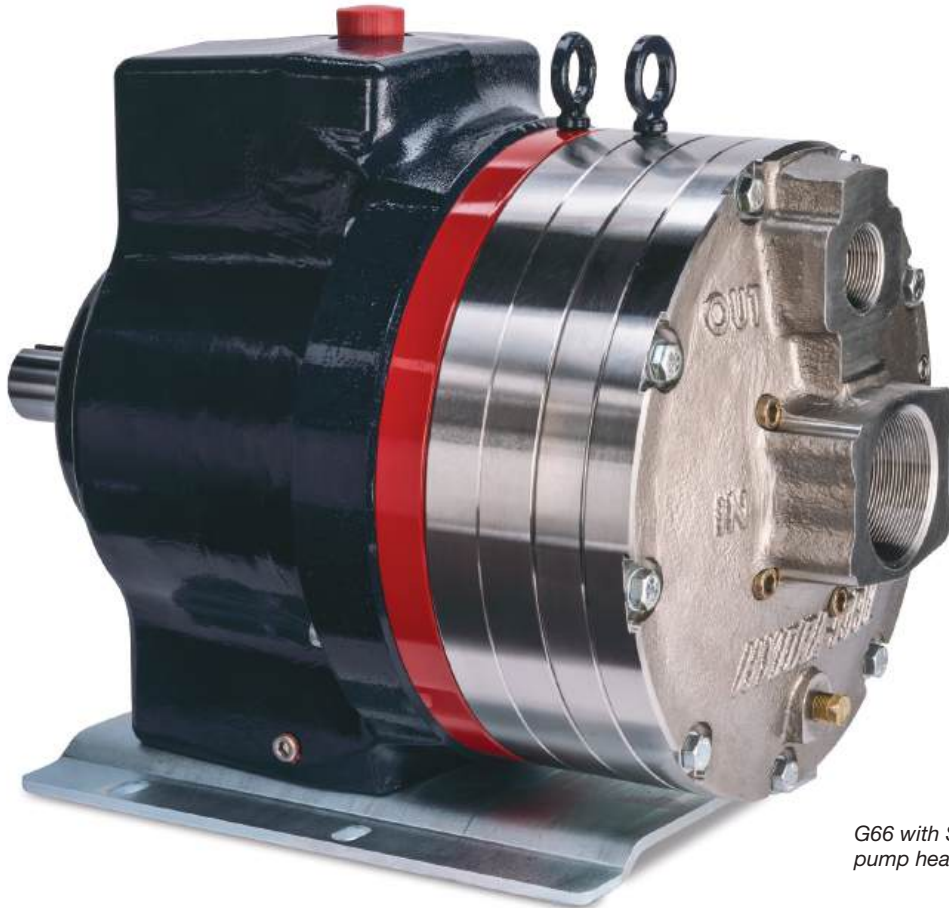

G66 with Stainless Steel pump head.

A higher standard of pump performance and energy efficiency.

- Integrates **Wanner Hydra-Cell® Pro** seal-less pump technologies for the highest levels of volumetric and energy efficiencies, up to 90% across the full rpm range.
- Reliably handles a wide range of viscosities and shear sensitivities, corrosive liquids, abrasives, slurries and suspended solids.
- No mechanical dynamic seals, packing, or cups to leak, wear or replace – reduces maintenance, costs and downtime.
- Can run dry indefinitely without damage to the pump.
- Seal-less design API 674 pumps that also exceed API 675 standards for accuracy, linearity and repeatability.
- Pumped media is 100% contained – prevents degradation, contamination and environmental risks.
- Patented ADPC (Advanced Diaphragm Position Control) and hydraulic oil management system protect diaphragms under closed or restricted inlet conditions.
- Reduced ownership costs – acquisition, operation, service, maintenance, and energy use.

G66 Pro Series | Performance

Capacities

Model	Max. Input		Max. Flow Capacities @69 bar (1000 psi)		Max. Inlet Pressure				Max. Discharge Pressure			
	rpm	USgpm	l/min	BPD	Metallic Heads		Non-Metallic Heads		Metallic Heads		Non-Metallic Heads	
					bar	psi	bar	psi	bar	psi	bar	psi
G66-X	1000	62.5	236.6	2142	17	250	3.4	50	69	1000	17	250

Performance and specification ratings apply to G66 configurations unless specifically noted otherwise.

Available to Meet API 674

Please contact Wanner International for further information.

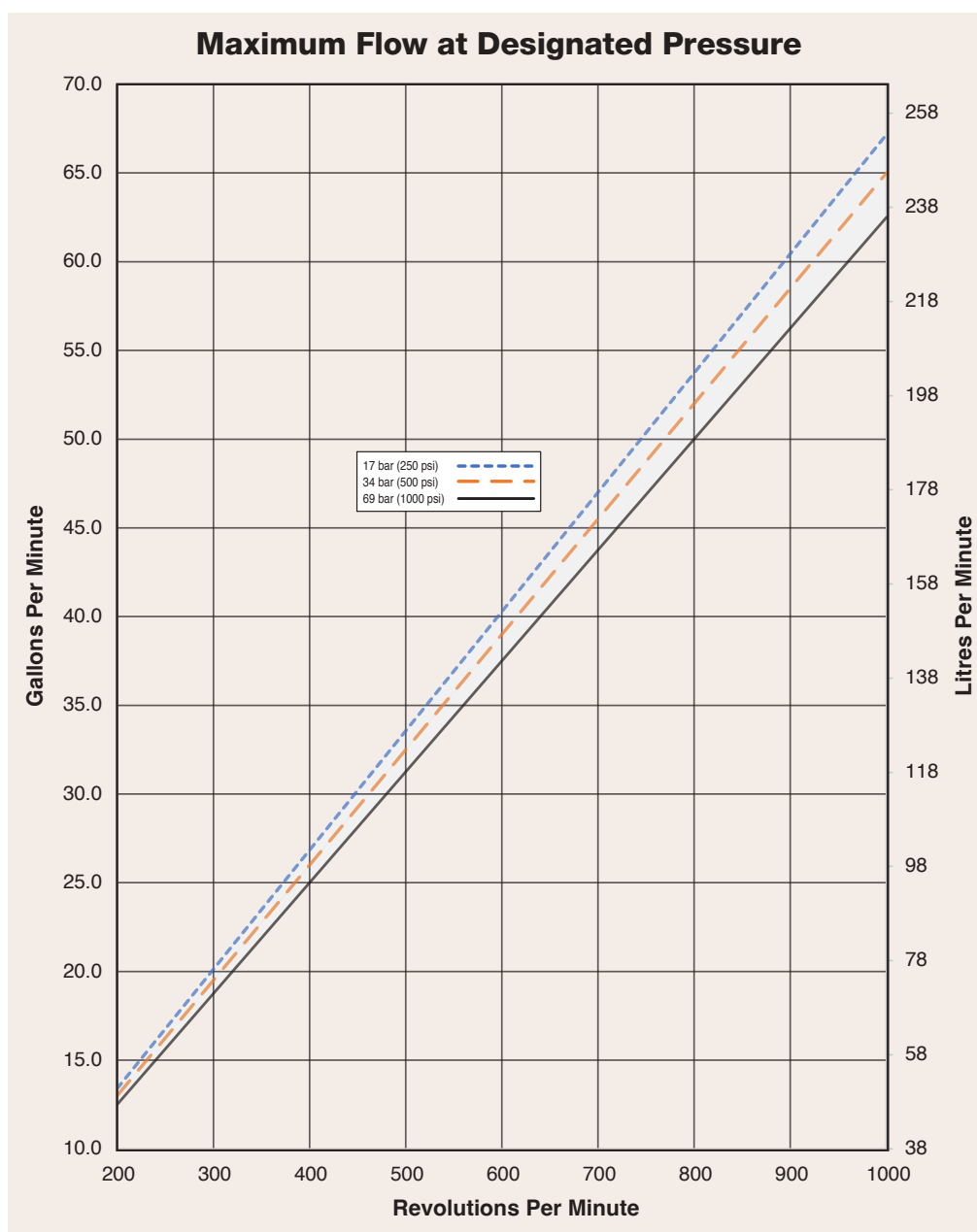

- True positive displacement pumping action achieves overall efficiency of >90%, targeting improvements at lower speeds and higher pressures.

Due to the Wanner Engineering Continuous Improvement Program, specifications and other data are subject to change.

G66 Pro Series | Specifications

Flow Capacities @ 17 bar (250 psi)

Model	rpm	l/min	USgpm	BPD
G66-X (Non-metallic)	1000	253.2	66.9	2293

Flow Capacities @ 34 bar (500 psi)

Model	rpm	l/min	USgpm	BPD
G66-X (Metallic)	1000	246.1	65.0	2228

Flow Capacities @ 69 bar (1000 psi)

Model	rpm	l/min	USgpm	BPD
G66-X (Metallic)	1000	236.6	62.5	2142

Delivery @ 17 bar (250 psi)

Model	litres/rev	gal/rev
G66-X (Non-metallic)	0.253	0.0669

Delivery @ 34 bar (500 psi)

Model	litres/rev	gal/rev
G66-X (Metallic)	0.246	0.0650

Delivery @ 69 bar (1000 psi)

Model	litres/rev	gal/rev
G66-X (Metallic)	0.237	0.0625

Maximum Discharge Pressure

Metallic Heads	69 bar (1000 psi)
Non-metallic Heads:	17 bar (250 psi)

Maximum Inlet Pressure

Metallic Heads:	17 bar (250 psi)
Non-metallic Heads:	3.4 bar (50 psi)

Maximum Operating Temperature

Metallic Heads:	93.3°C (200°F) Consult factory for correct component selection for temperatures from 71°C (160°F) to 93.3°C (200°F).
Non-metallic Heads:	49°C (120°F) Consult factory for temperatures above 49°C (120°F).

Maximum Solids Size

800 microns

Calculating Required Power

$$\frac{100 \times \text{rpm}}{63,000} + \frac{\text{gpm} \times \text{psi}}{1,460} = \text{electric motor hp}$$

$$\frac{100 \times \text{rpm}}{84,428} + \frac{\text{l/min} \times \text{bar}}{511} = \text{electric motor kW}$$

Attention!

When using a variable frequency drive (VFD) controller, calculate the hp or kW at minimum and maximum pump speed to ensure the correct hp or kW motor is selected. Note that motor manufacturers typically de-rate the service factor to 1.0 when operating with a VFD.

Calculating Pulley Size

$$\frac{\text{motor pulley OD}}{\text{pump rpm}} = \frac{\text{pump pulley OD}}{\text{motor rpm}}$$

Inlet Port

3 inch BSPT (Metallic)
3 inch NPT (Metallic)
2-1/2 inch SAE J518 Flange (Non-metallic)
3 inch SAE J518 Flange (Metallic)

Discharge Port

1-1/2 inch BSPT
1-1/2 inch NPT
1-1/2 inch SAE

Shaft Diameter

50.8 mm (2 inch)

Shaft Rotation

Reverse (bi-directional)

Bearings

Tapered roller bearings

Oil Capacity

10.4 litres (11 US quarts)

Weight

Metallic Heads: 181 kg (400 lbs.)
Non-metallic Heads: 125 kg (275 lbs.)

Net Positive Suction Head (NPSHr)

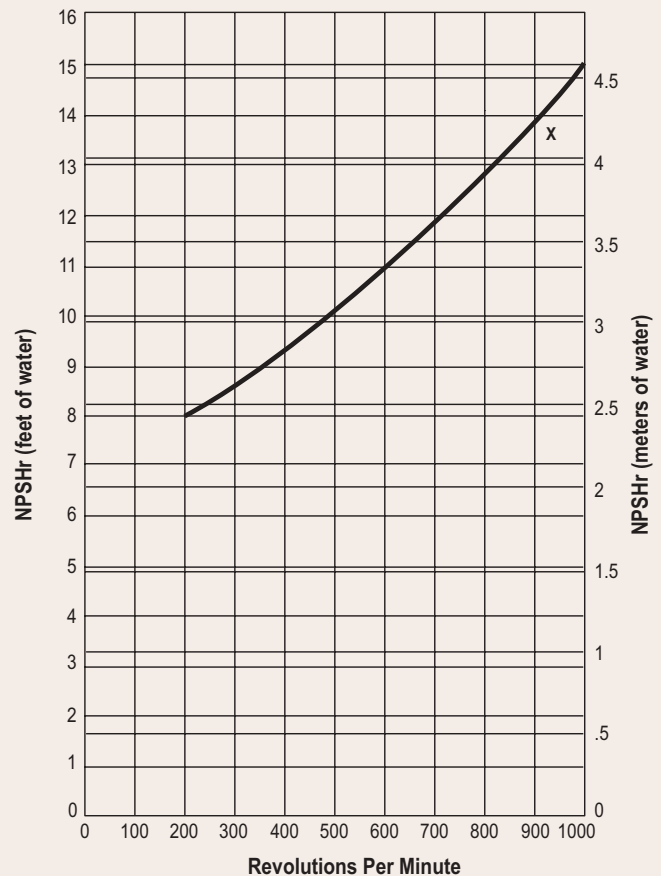

Suction Lift

Each Hydra-Cell pump has different lift capability depending on model size, cam angle, speed, and fluid characteristics. To ensure that your specific lift characteristics are met, refer to the inlet calculations regarding friction, and acceleration head losses in your Hydra-Cell Product Manual. Compare those calculations to the NPSHr curves above.

Due to the Wanner Engineering Continuous Improvement Program, specifications and other data are subject to change.

G66 Pro Series | Representative Drawings

G66 Models with SAE Flange Inlet/Outlet Ports mm (Inches)

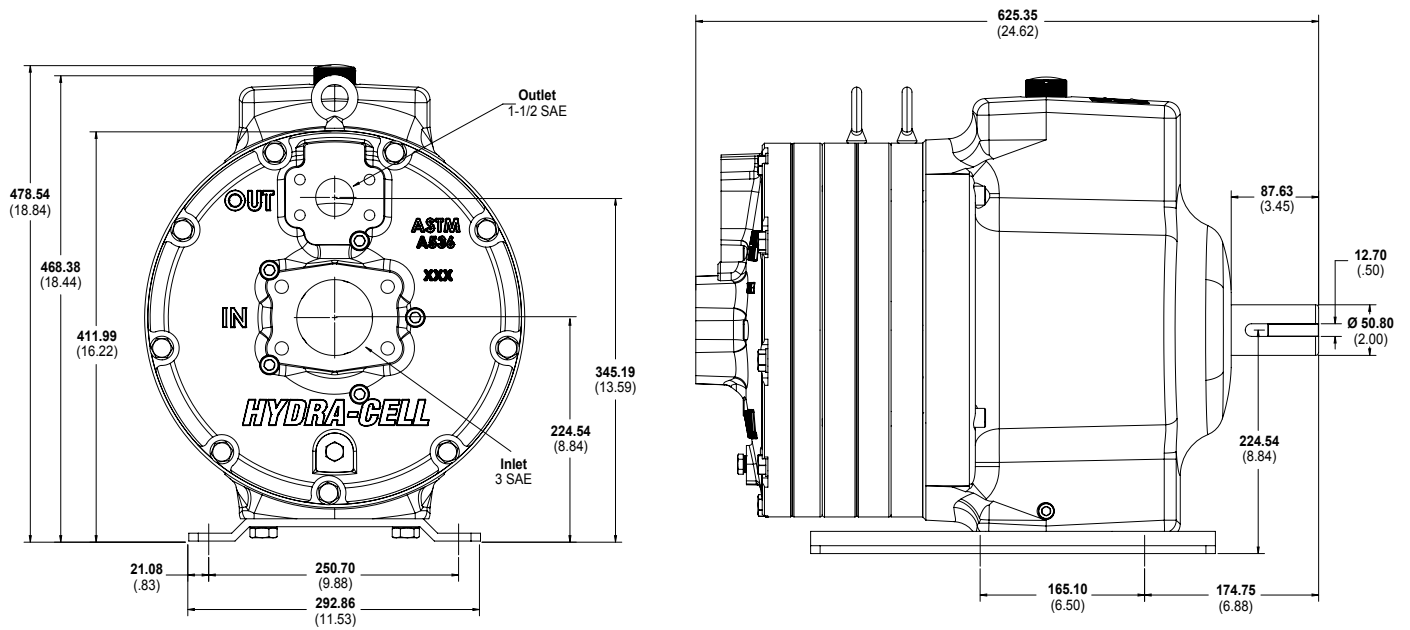

Metallic pump head models shown.

G66 Models with SAE Flange Inlet/Outlet Ports mm (Inches)

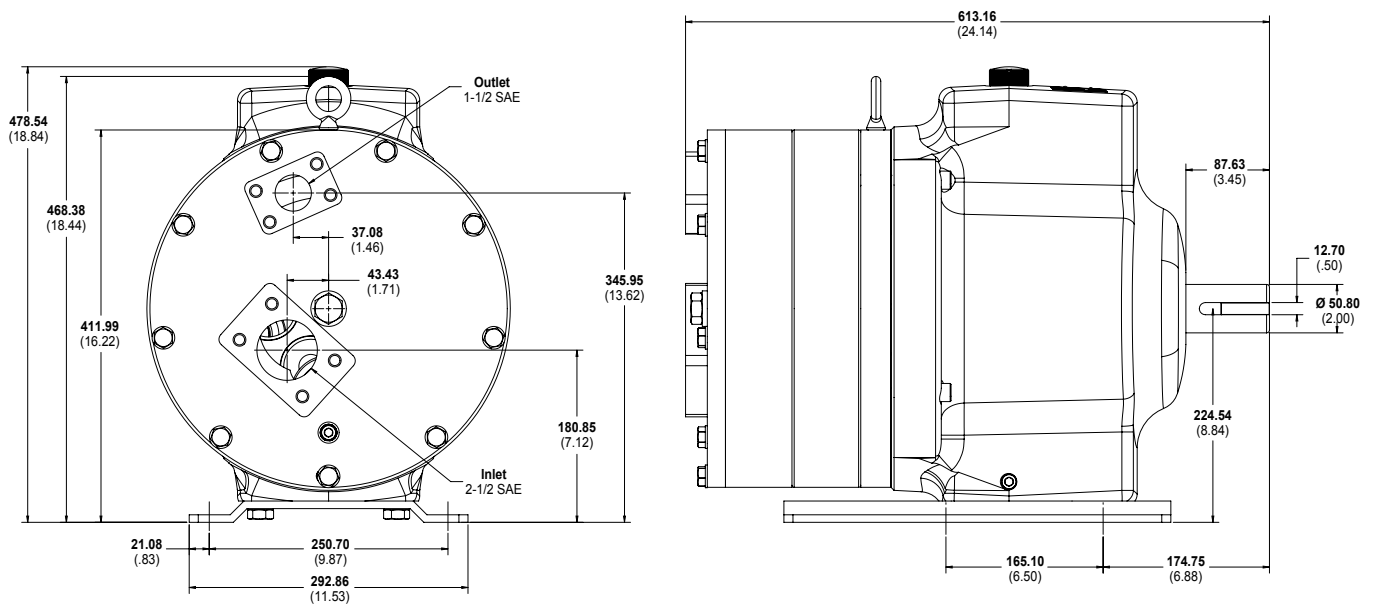

Non-metallic pump head models shown.

Note: Dimensions are for reference only. Contact factory for certified drawings.

G66 Pro Series | Representative Drawings

G66 Models with BSPT Inlet/Outlet Ports mm (Inches)

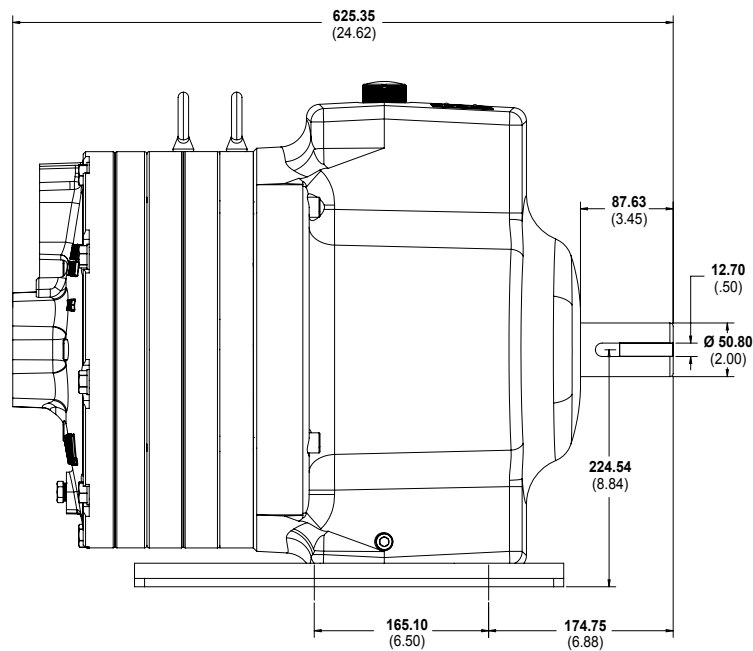
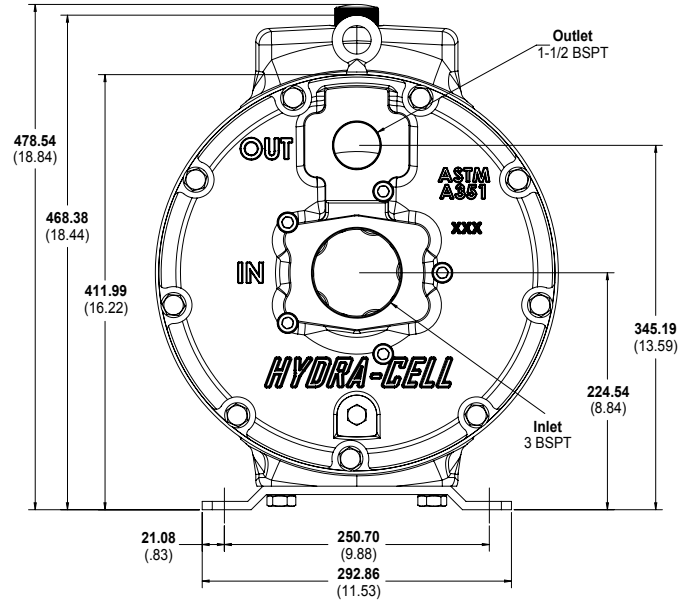

Metallic pump head models shown.

Note: Dimensions are for reference only. Contact factory for certified drawings.

G66 Pro Series | Options

Contact Wanner International for:

- Motors, bases, couplings and other pump accessories
- Hydra-Oil selection and specification information
- Design considerations, installation guidelines, and other technical assistance in pump selection
- Flange adapter for ANSI and DIN flange
- Process liquid end built with NACE and 3.1 traceable material certification
- Flange adapter for ANSI and DIN flanges



G66 with Brass pump head and threaded ports.



G66 with Brass pump head and SAE flanged ports



G66 with Stainless Steel pump head.



G66 with Polypropylene pump head.

G66 Pro Series | How to Order

Ordering Information

A complete G66 Series Model Number contains 12 digits including 8 customer-specified design and materials options, for example: G66XKSGHFHMH.

1	2	3	4	5	6	7	8	9	10	11	12
	6	6	X								





Digit	Order Code	Description	Digit	Order Code	Description
1-3		Pump Configuration	10		Valve Springs
	G66	Shaft-driven (BSPT Ports)		E	Elgiloy
	D66	Shaft-driven (SAE Flanged Ports)		T	Hastelloy C
4		Hydraulic End Cam	11		Valve Spring Retainers
	X	Max. 236.6 l/min (62.5 USgpm) 2142 BPD @ 1000 rpm		C	Celcon
5		Pump Head Version		M	PVDF
	P	Hydra-Cell Pro	12		Hydra-Oil
	E	Hydra-Cell Pro SAE Flanges		C	EPDM-compatible oil
6		Pump Head Material		H	15W50 high-temp severe-duty synthetic oil
	B	Brass			
	C	Ductile Iron (Nickel-plated)			
	G	Duplex Alloy 2205 Stainless Steel (with Hastelloy C followers & follower screws)			
	N	Polypropylene (with Hastelloy C followers and follower screws) - SAE only			
	S	316L Stainless Steel			
7		Diaphragm & O-ring Material			
	E	EPDM (used with metallic heads only)			
	R	EPDM (used with non-metallic heads only)			
	G	FKM (used with metallic heads only)			
	H	FKM (used with non-metallic heads only)			
	T	Buna-N (used with metallic heads only)			
	U	Buna-N (used with non-metallic heads only)			
8		Valve Seat Material			
	H	17-4 Stainless Steel			
	C	Ceramic			
	N	Nitronic 50			
	T	Hastelloy C			
9		Valve Material			
	F	17-4 Stainless Steel			
	C	Ceramic			
	N	Nitronic 50			
	T	Hastelloy C			

Partners in over 70 countries



WANNER™
Global Sales and Technical Support



Americas

-  Minneapolis, Minnesota USA
-  Wichita Falls, Texas USA
-  São Paulo, Brazil
-  Buenos Aires, Argentina

EMEA | Australia

-  Hampshire, United Kingdom
-  Cairo, Egypt
-  Düsseldorf, Germany
-  Lyon, France

Asia | Pacific

-  Kowloon, Hong Kong
-  Shanghai, China
-  Jakarta, Indonesia

India

-  Mumbai, India
-  New Delhi
-  Bangalore
-  Gujarat

Wanner worldwide

GLOBAL SALES & TECHNICAL SUPPORT

WANNER ENGINEERING, INC.

WORLD HEADQUARTERS & MANUFACTURING

Minneapolis, Minnesota USA
t: 612-332-5681
e: sales@wannereng.com
Hydra-Cell.com

REGIONAL OFFICE

Wichita Falls, Texas USA
t: 940-322-7111
e: sales@wannereng.com

LATIN AMERICAN OFFICE

São Paulo, Brazil
t: +55 (11) 99582-1969
e: mmagoni@wannereng.com
Hydra-Cell-Pumps.com.br

WANNER INTERNATIONAL, LTD.

UNITED KINGDOM

Church Crookham, Hampshire UK
t: +44 (0) 1252 816847
e: support@wannerint.com
Hydra-Cell.co.uk

WANNER PUMPS, LTD.

Kowloon, HONG KONG
t: +852 3428 6534
e: sales@wannerpumps.com
WannerPumps.com

Shanghai, CHINA
t: +86-21-6876 3700
e: sales@wannerpumps.com
WannerPumps.com

WANNER INDIA PVT. LTD.

Mumbai, INDIA
t: +91 (22) 22044766
e: support@wannerindia.com
WannerIndia.com

