



# Hydra-Cell<sup>®</sup>

Seal-less Pump Technology

## Machine Tool

Reduce operating costs and  
maximise productivity



# Hydra-Cell® Seal-less High Pressure Coolant Pumps

The most energy efficient, high pressure coolant pump with ultimate controllability and lowest cost of ownership.



Stand-alone/high pressure coolant systems

Grinding  
Wheel cleaning/dressing



Parts cleaning



Degreasing



Deburring





Wanner has over 40 years experience in design, manufacturing and supplying Hydra-Cell high pressure coolant pumps into the metal cutting industry; supporting customers globally.

Maximise productivity with Hydra-Cell seal-less design - the most energy-efficient, high pressure coolant pump for your machine tool processes, whether you are an end user, CNC machine builder, high pressure coolant or filtration manufacturer.



Electrical discharge machining (EDM)



Turning and threading



Milling



Deep hole drilling



Multi-function machining

- Neat oils • Synthetic and semi-synthetic water mix fluids
- Milky soluble oils • Coolants containing particles and abrasives
- Recycled cleaning chemicals • De-ionized water

# Hydra-Cell®

## MACHINE TOOL COOLANT PUMPS

From neat oils, very low viscosity water based and synthetic coolants, Hydra-Cell high pressure coolant pumps deliver a consistent predictable performance.



Typical Chemicals and Liquids Pumped	Challenges in Pumping	The Hydra-Cell® ADVANTAGE
<b>EDM Fluids...</b> De-ionised water, Paraffinic hydrocarbon oils	<ul style="list-style-type: none"> <li>• May contain particles and fines</li> </ul>	<ul style="list-style-type: none"> <li>• Seal-less design can tolerate solids up to 500 µm in diameter, also high percentage of sub-micron particles</li> </ul>
	<ul style="list-style-type: none"> <li>• Chemically aggressive and non-lubricating, can cause problems for pumps with dynamic seals</li> </ul>	<ul style="list-style-type: none"> <li>• Eliminates seal and packing maintenance when pumping corrosive and non-lubricating liquids</li> </ul>
<b>Milky soluble oil emulsions</b>	<ul style="list-style-type: none"> <li>• Water thin, can cause premature wear of dynamic seals immersed in the coolant, resulting in lost pressure</li> </ul>	<ul style="list-style-type: none"> <li>• Seal-less, true positive displacement design pumps viscous and water thin liquids equally well</li> </ul>
	<ul style="list-style-type: none"> <li>• May contain abrasive metal fines</li> </ul>	<ul style="list-style-type: none"> <li>• Seal-less design can tolerate solids up to 500 µm in diameter, also high percentage of sub-micron particles</li> </ul>
	<ul style="list-style-type: none"> <li>• May become aerated causing localised dry running conditions</li> </ul>	<ul style="list-style-type: none"> <li>• Can run dry indefinitely without damage</li> </ul>
<b>Neat oils...</b> Hydrocarbon or synthetic	<ul style="list-style-type: none"> <li>• May contain abrasive metal fines</li> </ul>	<ul style="list-style-type: none"> <li>• Seal-less design can tolerate solids up to 500 µm in diameter, also high percentage of sub-micron particles</li> </ul>
<b>Synthetic and semi-synthetic water mix fluids</b>	<ul style="list-style-type: none"> <li>• May have poor lubricating properties causing premature wear of dynamic seals immersed in the coolant, resulting in lost pressure</li> </ul>	<ul style="list-style-type: none"> <li>• Hydra-Cell® does not rely on pumped liquid for internal lubrication</li> <li>• Always delivers a constant pressure and flow rate</li> </ul>
	<ul style="list-style-type: none"> <li>• May become aerated causing localised dry running conditions</li> </ul>	<ul style="list-style-type: none"> <li>• Can run dry indefinitely without damage</li> </ul>
	<ul style="list-style-type: none"> <li>• May contain abrasive metal fines</li> </ul>	<ul style="list-style-type: none"> <li>• Seal-less design can tolerate solids up to 500 µm in diameter, also high percentage of sub-micron particles</li> </ul>

# Hydra-Cell®

## ADVANTAGES

## LOWEST LIFE CYCLE COSTS



### How does Hydra-Cell pump technology reduce life cycle costs?

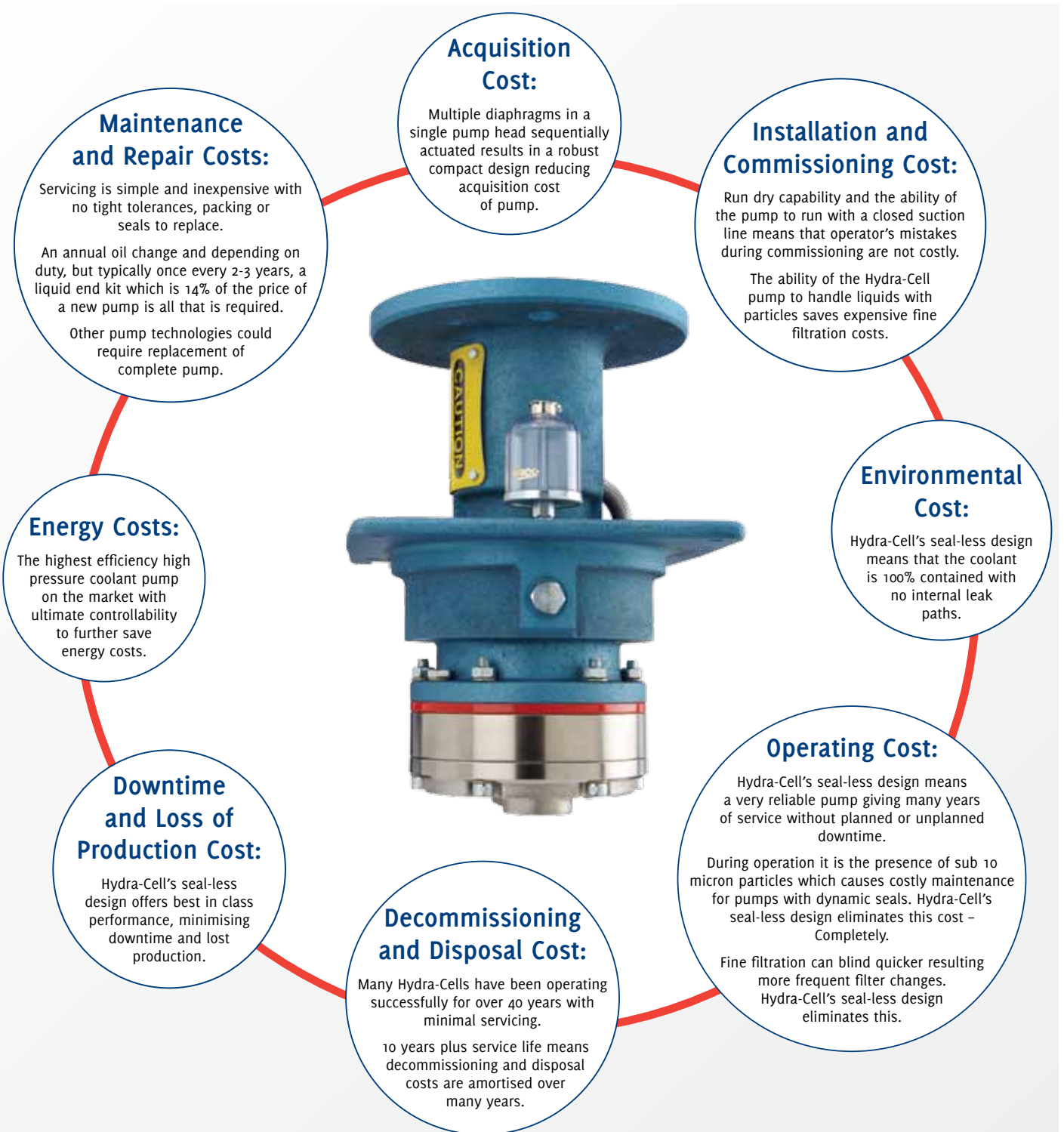

## Reliable pumping of particles and fines

With its unique seal-less design, Hydra-Cell pumps reliably handle neat oils, very low viscosity water-based and synthetic coolants as well as coolants containing particles and abrasives.

### Reliably handling coolant with suspended metal particles

Typically coolant filtration systems will filter down to 10 microns, however damage to coolant pumps with dynamic seals is often caused by having higher ppm of sub-10 micron particles. Hydra-Cell seal-less design eliminates this issue reducing operating and lifetime costs and increasing productivity.

Hydra-Cell seal-less design allows the pump to handle liquids with suspended solids from 0.1 microns up to 500 microns, reliably and consistently over many years. The wide choice of valve materials, such as ceramic and tungsten carbide, enables processing of materials ranked 10 on the Mohs' hardness scale, such as diamond.

Electrical Discharge Machining (EDM) is used widely to process very hard materials that are difficult to machine by conventional means. The dielectric fluid cools the process and removes the abrasive, eroded particles that block fine filtration and can destroy pumps with dynamic seals.

Hydra-Cell pumps are unaffected by these entrained abrasive particles and are ideal for EDM hole drilling and wire or sinker EDM.



### Grinding

In high speed production grinding, high pressure coolant provides optimum cooling and flushing of the contact area of the grinding wheel and the work piece.

High pressure coolant should also be pumped onto the surface of the grinding wheel to free the abrasive matrix, prevent wheel glazing and loading.

The coolant often contains particles of the work piece as well as abrasive grains from the grinding wheel. Conventional centrifugal, screw or piston pumps have trouble pumping this recycled fluid but Hydra-Cell coolant pumps handle these particles with ease.

### Cleaning and degreasing

High pressure cleaning reduces the amount of cleaning chemistry used, lowers the volume of waste stream generated and reduces energy consumption.

With a wide choice of liquid head materials Hydra-Cell seal-less pumps are well equipped to handle the wide variety of cleaning chemicals and solvents used and are unaffected by particles that become entrained in recirculating systems.

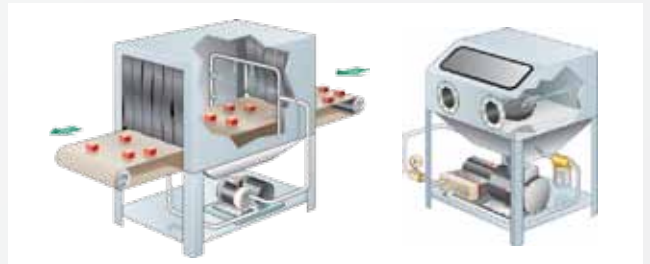

### Deburring

High Pressure Water Deburring (HPWD) removes chips, burrs and flashing and generates an abundance of abrasive fines that cause expensive seal wear in pumps with dynamic seals. Hydra-Cell seal-less pumps have no requirement for expensive seal flushing, even at the high pressures the process requires.

### Flow Rate Comparison

Variation of flow rate with pressure  
(Pumps running at a fixed rpm)

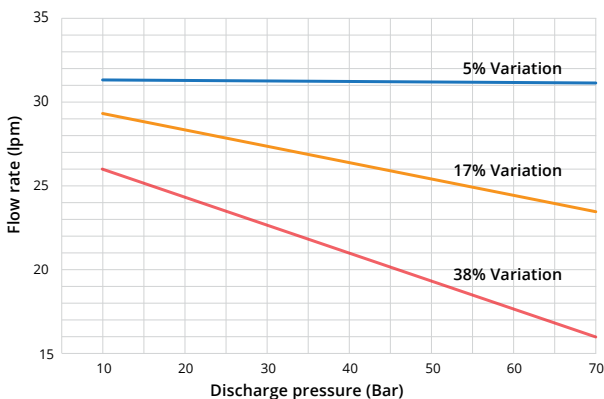

- Hydra-Cell G10 - Water based and Neat Oil coolants
- Screw pump - Neat Oil coolants
- Screw pump - Water based coolants



# Hydra-Cell®

## ADVANTAGES AND FEATURES

Drilling

Turning

Milling

## Consistent flow rate independent of discharge pressure and fluid viscosity

Hydra-Cell seal-less, high pressure coolant pumps deliver a consistent, predictable performance, year after year.

### Consistent predictable process

The key to machining quality, productivity and process predictability is the consistency of the coolant delivered at the cutting zone.

Hydra-Cell's seal-less design means that consistent predictable coolant flow rates are achievable, even with particles present in the coolant.

### Maintaining flow irrespective of pressure

Pumps with internal, close tolerance dynamic seals, such as screw and gear pumps lose efficiency as pressures increase or as internal wear takes its toll.

Hydra-Cell coolant pumps have no internal flow losses and no dynamic seals or internal bearings to wear, guaranteeing optimum efficiency and consistent predictable coolant flow rates year in, year out, irrespective of system pressure.

#### Hydra-Cell pump chamber with No Dynamic Seals

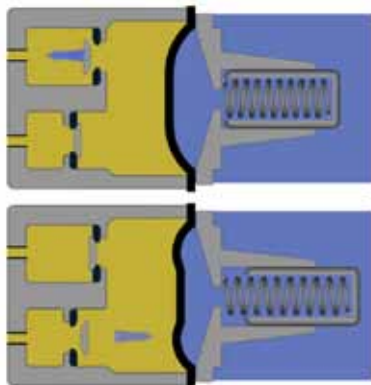

### Maintaining pumping efficiency irrespective of fluid viscosity

Different cutting tool liquids can vary in viscosity from thick oils at 20mm<sup>2</sup>/s to emulsions and synthetic water-based coolants at 1 mm<sup>2</sup>/s.

Pumps that rely on the coolant for internal sealing, such as screw and gear pumps, are significantly less efficient at pumping water based fluids than neat oils.

With no dynamic seals or internal flow losses, Hydra-Cell pumps are equally efficient whether pumping neat oils or water-mix coolants.

### Turning and milling

Hydra-Cell pumps are true positive displacement pumps, eliminating the internal flow losses suffered by screw and gear pumps and enabling overall efficiencies of 78% - 90% (pump-shaft to hydraulic power) to be achieved. This results in significant energy savings that repeat year after year.

Able to run dry without damage and having no dynamic seals to wear, Hydra-Cell high pressure coolant pumps are extremely durable and require little maintenance.

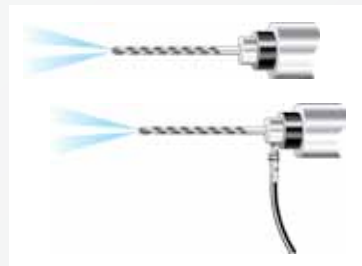

### Deep hole drilling

In deep hole drilling, coolant must be pumped to the end of the drill in order to cool the bit, flush the chips and reduce deflection of the tool to maintain tolerances.

Hydra-Cell high pressure coolant pumps maintain the required flow rate independent of pressure, right to the bottom of the hole, optimising drilling performance.

Fine filtering coolant to meet the requirements of other coolant pumps can be expensive and cumbersome but Hydra-Cell pumps operate efficiently without such filtration.

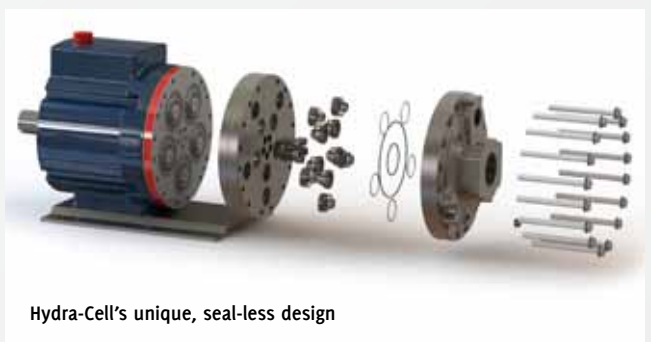

Hydra-Cell's unique, seal-less design

Grinding

Cleaning and Degreasing

Deburring

Drilling

Turning

Milling

## Reducing energy costs and total lifecycle costs

The highest efficiency, high pressure coolant pump on the market with ultimate controllability to further save energy costs.

### Energy efficient for reduced energy costs

Being a true positive displacement pump, the seal-less design of the Hydra-Cell pump eliminates internal flow losses giving overall efficiencies of 78% - 90% (pump-shaft to hydraulic power) resulting in significant energy savings; with no dynamic seals, this is consistent year after year.

### Further energy savings

The flow rate of the Hydra-Cell pump is directly proportional to the pump shaft RPM. This results in a very controllable and accurate flow rate, independent on coolant technology and operating discharge pressure.

This means that the Hydra-Cell high pressure coolant pump controls the flow rate consistently and accurately to only deliver the exact coolant the machine tool needs to develop the process pressure, no more no less.

Because of these pump properties this can be achieved with simple open loop control, no need for pressure sensors making retrofitting to existing machines very simple.

### Optimise performance for optimised energy savings

Variations in tool size require different coolant flow rates, with Hydra-Cell's Intelligent Pump Control solution the coolant is only delivered exactly when it's needed in the exact quantity and at the exact pressure. Significant energy savings achieved:

- eliminating the need for coolant bypass.
- dramatically reducing coolant heating savings energy on chiller units.

Turn to page 9 for full details on the advantages of the Hydra-Cell High Pressure Coolant Pumps with Intelligent Pump Control (patent pending).

### Coolant bypass can be eliminated saving up to 70% of energy

- Not pumping excess coolant.
- Less coolant heating, less energy used by the coolant chiller.

Pump-Shaft to hydraulic power efficiency

Save up to **42%** on your energy bill with Hydra-Cell

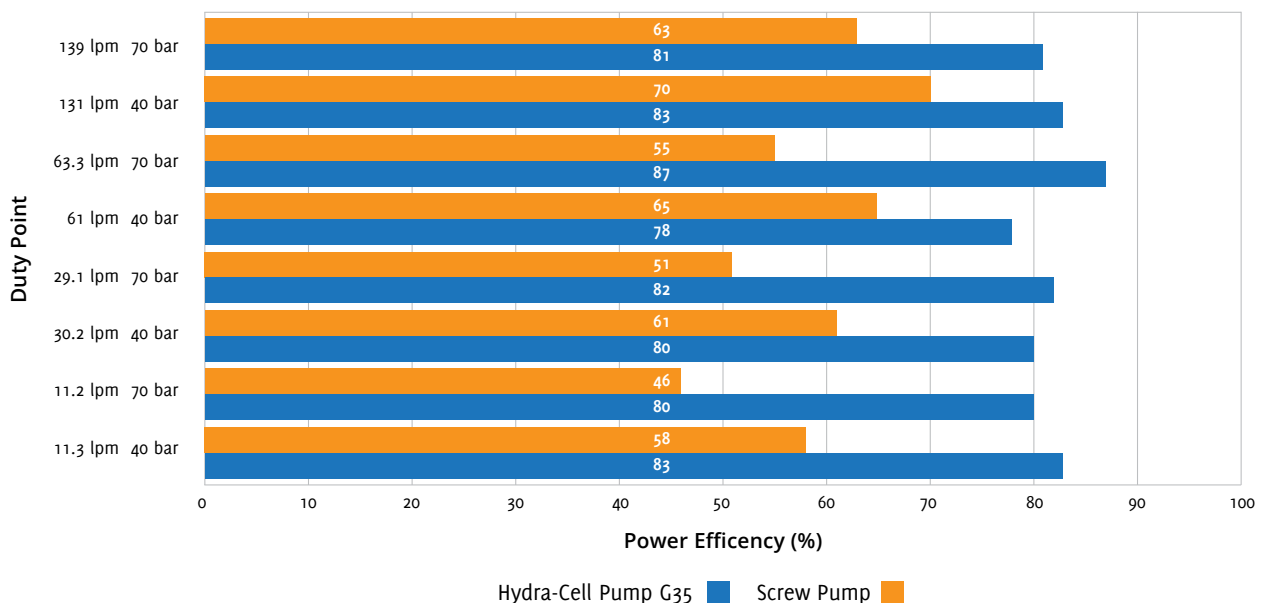

Note: efficiencies are calculated assuming water based coolants. 4 pole motors were used due to the highest efficiency.



Grinding

Cleaning and Degreasing

Deburring

Drilling

Turning

Milling

## Long life and minimal maintenance costs

Any servicing is simple. With no dynamic seals wearing or tight internal tolerances to set or maintain, servicing can be carried out in any basic workshop. Depending on the duty, all that is required is an annual oil change and a liquid end kit replaced once every 2-3 years (€300 to €700 depending on specification). A true "fit and forget" solution.

Lifetime Costs Comparison (5 years)\*

Save **33%** on total lifetime costs with Hydra-Cell

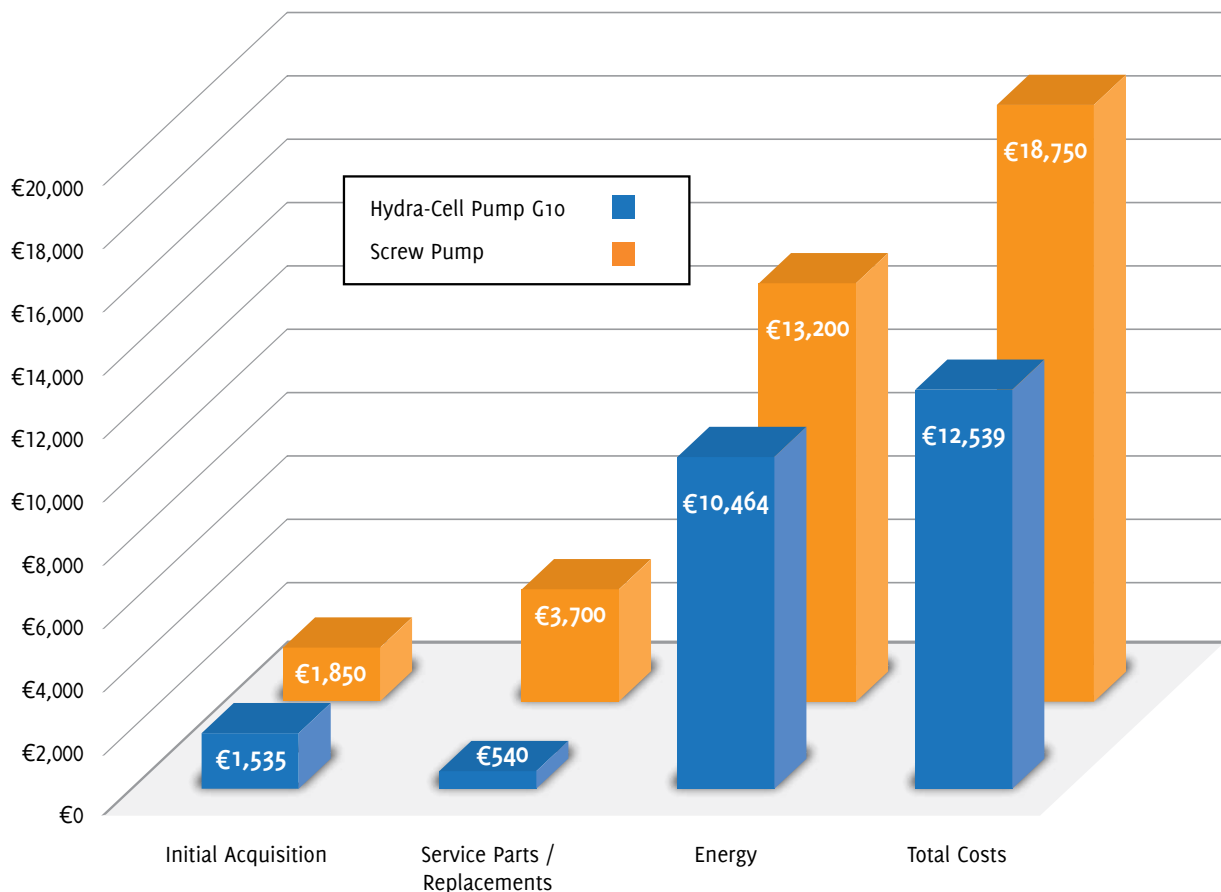

\* Lifetime costs comparison is based on a machine tool coolant application with the pump running at 103 lpm at 70 bar.

Energy costs based on 103 lpm 70 bar running 4,000 hours per annum at 12 Euro Cents per kWh. Figures represent the average user who wants to maintain the process discharge pressure by +/- 10% and has adopted a simple filtration management system and specification. Calculations do not take into account motor efficiencies. A traditional screw pump typically needs replacing after 24 months due to seal and plain bearing wear.

Where replacement parts are not available a complete pump replacement is necessary. The Hydra-Cell seal-less pump only requires minimal servicing and depending on duty, may only require a replacement fluid end kit once every two to three years.

Grinding

Cleaning and  
Degreasing

Deburring

Drilling

Turning

Milling

## Ultimate Controllability with Intelligent Pump Control

Increase productivity with the most energy-efficient, high-pressure coolant pump with ultimate controllability and the lowest cost of ownership - Hydra-Cell® High Pressure Coolant Pumps with Intelligent Pump Control (patent pending).

### Simple installation and trouble-free operation

Easy “plug and play” solution

- Pump
- Motor and integrated controller
- Compatible with CNC communication protocols
- No external sensors



### Ultimate controllability independent of coolant type

Optimise your machine tool processes and increase productivity with Hydra-Cell for consistent delivery of coolant for consistent processes.

Hydra-cell seal-less, high pressure coolant pumps with Intelligent Pump Control automate and integrate performance data monitoring for full control, maximum efficiency, reliability and cost savings.

### Control and management

- Consistent delivery of coolant for a consistent process.
- Open loop control – no need for pressure sensors.
- Pressure and flow rate setting and monitoring – no sensor needed.
- Programme different pressures for different tools for different processes set by CNC machine main programme.
- Set-up automated alerts for service intervals to optimise productivity.

### Optimise performance for optimised energy savings

Variations in tool size require different coolant flow rates, with Hydra-Cell's solution the coolant is only delivered exactly when it's needed in the exact quantity and at the exact pressure, achieving significant energy savings.

- Eliminates the need for coolant bypass.
- Dramatically reduces coolant heating saving chiller costs.



## Energy saving comparison

Consider an example of a machining operation which is using three different tools that require three different coolant flow rates to achieve a process coolant pressure of 40 bar. 50% energy savings are achieved just on pumping the coolant. Further energy savings are made by reduced use of the chiller.

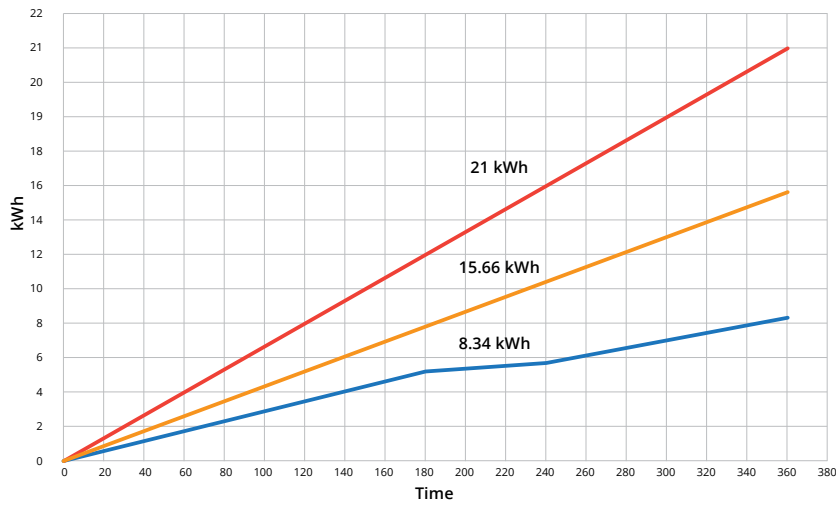

EXAMPLE: Machining cycle time 6 hrs  
 Tool 1 needs 20 lpm, for 3 hrs  
 Tool 2 needs 6 lpm, for 1 hrs  
 Tool 3 needs 15 lpm, for 2 hrs

— Typical screw pump usage  
 — Hydra-Cell pump  
 — Hydra-Cell Intelligent pump solution

With the introduction of Hydra-Cell's intelligent pump, never has it been easier to install and take advantage of Hydra-Cell's ultimate controllability of coolant flow rates. The intelligent pump eliminates wasteful coolant bypass completely, only delivering exactly the right amount of coolant to the chosen tool at the right time when it's needed, generating significant energy savings. [Watch the video at www.hydra-cell.eu/machinetool](http://www.hydra-cell.eu/machinetool)

## Consistent coolant delivery for consistent processes

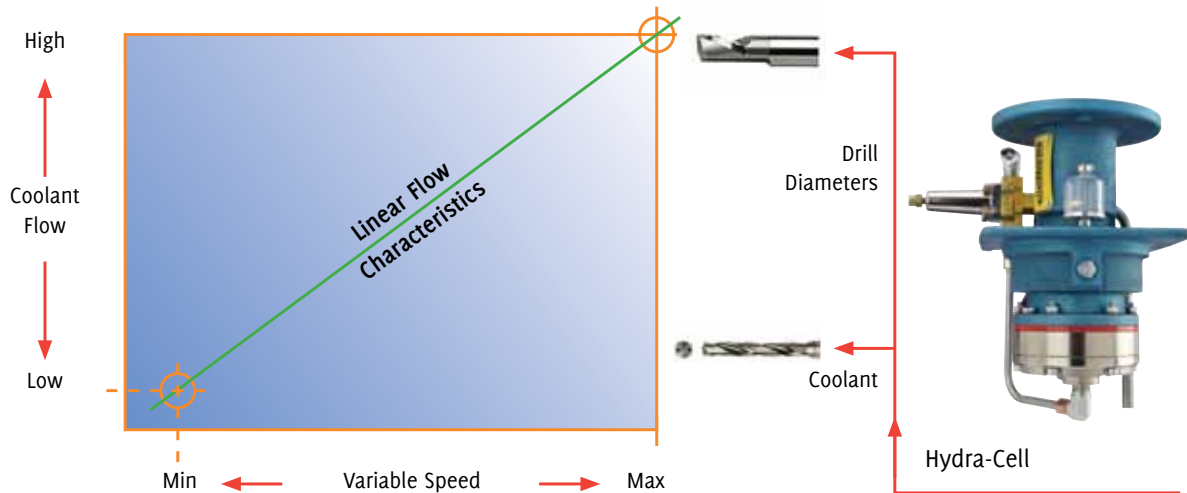

## Increase productivity and drastically reduce downtime

- Pre-programme service intervals for performance reliability and maintenance prevention.
- Set-up fault diagnosis alerts to detect adverse conditions to reduce downtime.

## Digital data management and integration

Pump performance data monitoring and reporting digitalised and integrated within your CNC machine data management system.

- Compatible with communication protocols: Profibus, Profinet, EtherNet/IP, EtherCat, CANopen, DeviceNet and Setpoint Converter.

## Open loop control of pump, no pressure sensors needed

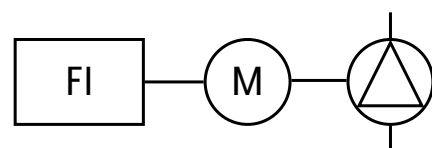

Grinding

Cleaning and Degreasing

Deburring

Drilling

Turning

Milling

## Comparing Hydra-Cell's energy requirements to those of other pump technologies

### Screw pumps

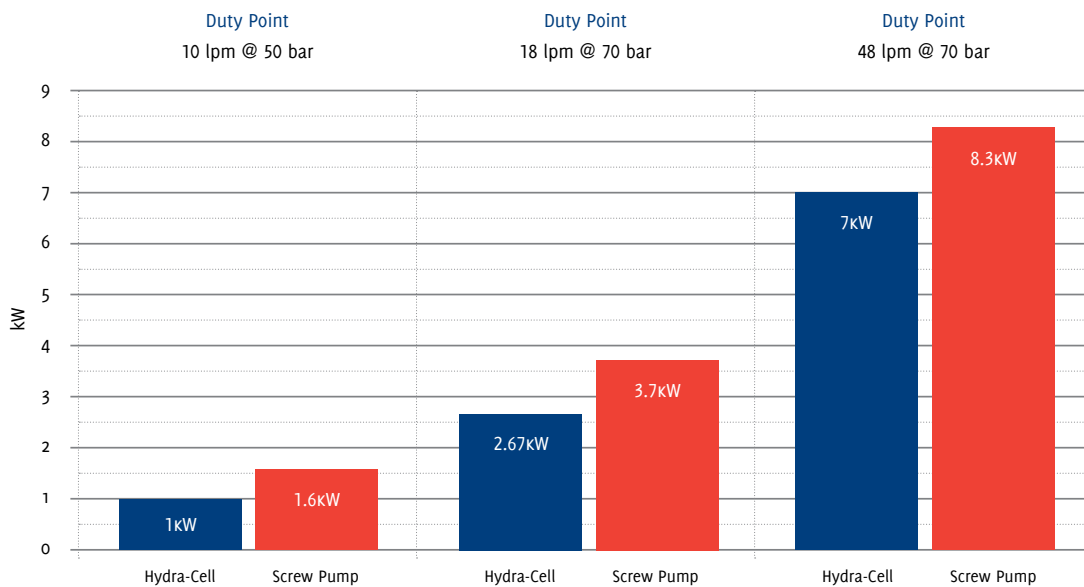

### Centralised Coolant System Using Horizontal Split Case Multistage Centrifugal Pumps

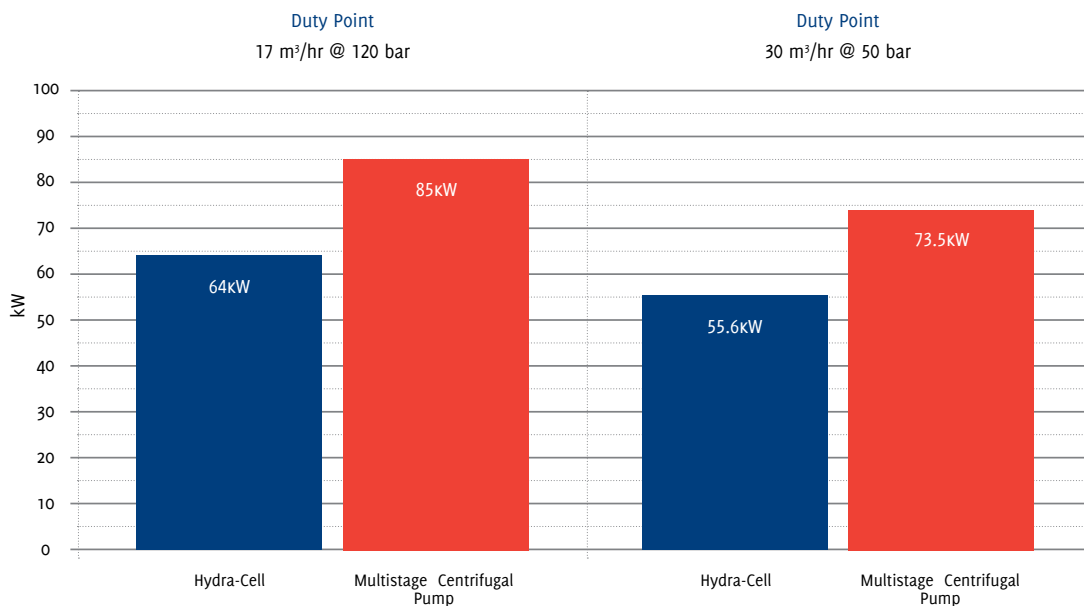



# Hydra-Cell®

## ADVANTAGES AND FEATURES

Grinding

Cleaning and  
Degreasing

Deburring

Drilling

Turning

Milling

## Why Hydra-Cell?

### Hydra-Cell's unique, seal-less design delivers real cost reductions

- Handles fines that can destroy pumps with dynamic seals.
- Requires no fine filtration.
- 10+ year's service life and minimal maintenance.
- Can run dry indefinitely.
- Up to 90% energy efficiency.
- True peace of mind with over 40 years partnering with world-class high pressure coolant manufacturers and the largest CNC machine tool manufacturers.



# Hydra-Cell® PERFORMANCE ADVANTAGES

## Compared to Screw Pumps

- No close tolerances so no need for fine filtration.
- Pumps thin and viscous liquids with equal efficiency.
- The seal-less design of Hydra-Cell® means that there are no seals or packing to leak or replace.
- Seal-less pumping chamber with spring-loaded, disk check valves can pump particles from 0.05 microns to 500 microns.
- Runs at very low speeds while maintaining outlet pressures, (from 5 to 1500 rpm) simplifying control functions.
- No requirement for the pumped liquid to seal or lubricate.
- No bushings in the pumped liquid.
- Can run dry without problem. Entrained air in the coolant does not lead to immediate failure.
- Ultimate controllability removes the need for bypass, saving energy and keeping the coolant cooler.
- Higher energy efficiencies.

## Compared to Centrifugal Pumps (Multi-stage)

- The seal-less design of Hydra-Cell® means that there are no seals or packing to leak or replace.
- Pumps coolants with abrasive particles with ease.
- Designed for high pressure delivery.
- Can run dry without problem. Entrained air in the coolant does not lead to immediate failure.
- Runs at very low speeds and maintains outlet pressures (from 5 to 1500 rpm).
- Higher energy efficiencies.

## Compared to External Gear Pumps

- The seal-less design of Hydra-Cell® means that there are no seals or packing to leak or replace.
- Seal-less pumping chamber and spring-loaded, disk check valves can pump coolants with abrasive particles with ease and unaffected by low viscosity coolants.
- No internal gears to wear so there is less maintenance and spare part replacement.
- Efficiency is more stable and does not degrade with time.
- No bushings in the pumped coolant.
- Design does not rely on clearances.
- Efficiency remains relatively constant over its range of operating pressures.
- Sealed liquid chamber requires no lubrication.



# Hydra-Cell® Principles of Operation - Wobble Plate

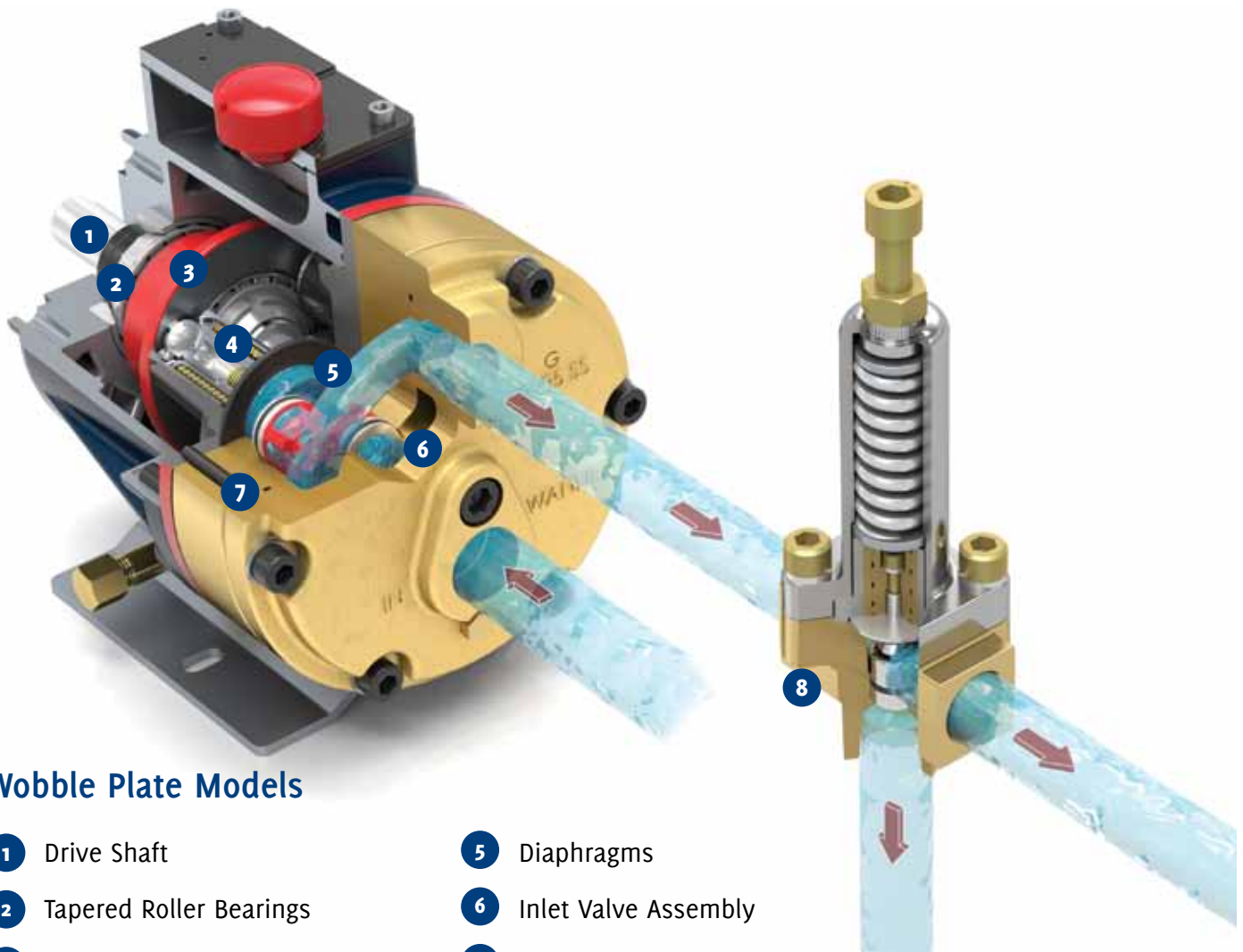

## Wobble Plate Models

- |                                |                                 |
|--------------------------------|---------------------------------|
| 1 Drive Shaft                  | 5 Diaphragms                    |
| 2 Tapered Roller Bearings      | 6 Inlet Valve Assembly          |
| 3 Fixed-angle Cam/Wobble Plate | 7 Discharge Valve Assembly      |
| 4 Hydraulic Cells (Patented)   | 8 C62 Pressure Regulating Valve |

## Reliable, Efficient Pumping Action

The drive shaft (1) is rigidly held in the pump housing by a large tapered roller bearing (2) at the rear of the shaft and a smaller bearing at the front of the shaft. Set between another pair of large bearings is a fixed-angle cam or Wobble Plate (3).

As the drive shaft turns, the swash plate moves, oscillating forward and back (converting axial motion into linear motion). The complete pumping mechanism is submerged in a lubricating oil bath.

The hydraulic cells (4) are moved sequentially by the Wobble plate and filled with oil on their rearward stroke. A ball check valve in the bottom of the piston ensures that the cell remains full of oil on its forward stroke.

The oil held in the Hydra-Cell balances the back side of the diaphragms (5) and causes the diaphragms to flex forward and back as the Wobble plate moves. This provides the pumping action.

To provide long trouble-free diaphragm life, Hydra-Cell hydraulically balances the diaphragm over the complete

pressure range of the pump. The diaphragm faces only a 0.21 bar pressure differential regardless of the pressure at which liquid is being delivered - up to 172 bar on standard Hydra-Cell models and Hydra-Cell metering pumps.

Hydra-Cell Wobble plate pumps can have up to five diaphragms, and each diaphragm has its own pumping chamber that contains an inlet and discharge self-aligning, disk check valve assembly (6). As the diaphragms move back, liquid enters the pump through a common inlet and passes through one of the inlet check valves. On the forward stroke, the diaphragm forces the liquid out the discharge check valve (7) and through the manifold common outlet. Equally spaced from one another, the diaphragms operate sequentially to provide consistent, low-pulse flow.

A Hydra-Cell C62 pressure regulating valve (8) is typically installed on the discharge side of the pump to regulate the pressure of downstream process or equipment.



# Hydra-Cell® Principles of Operation - Crankshaft

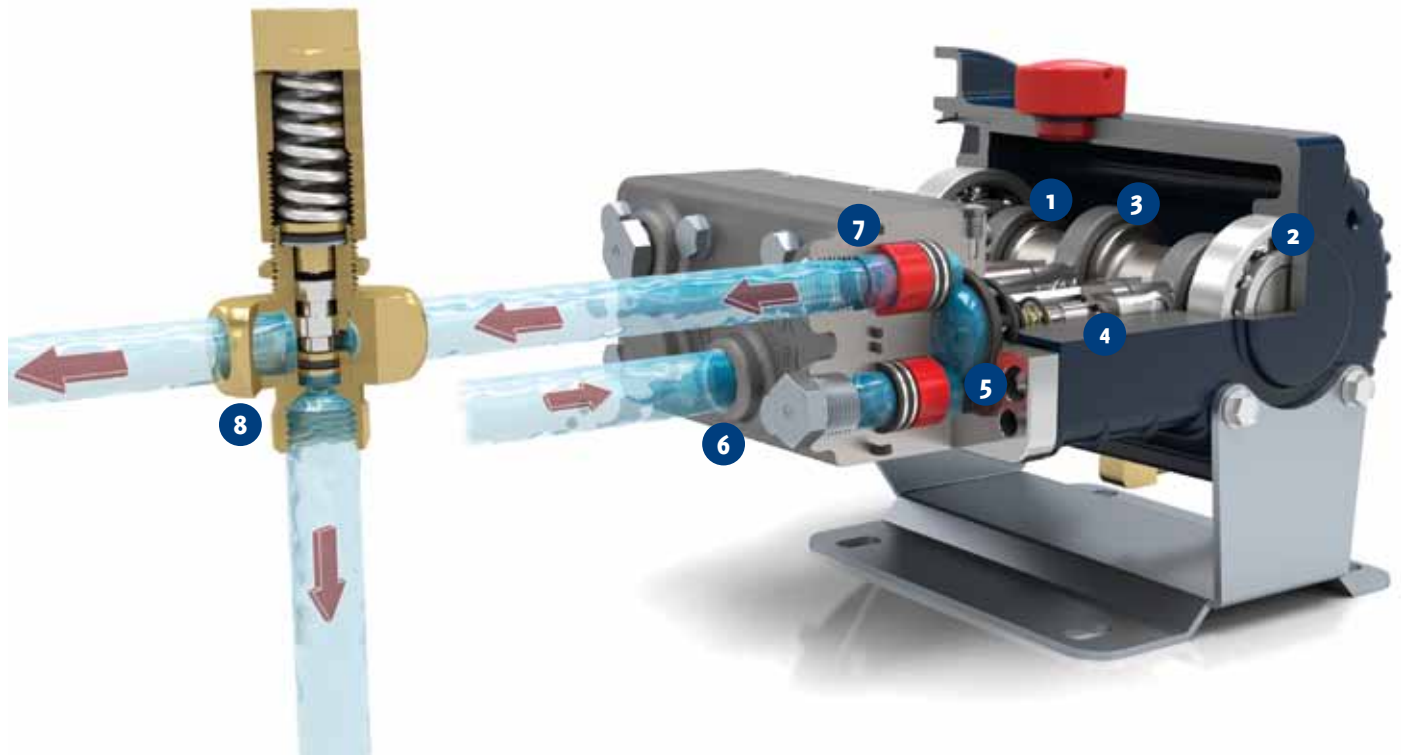

## Crank-shaft Models

- |                              |   |
|------------------------------|---|
| 1 Drive Shaft                | 5 Diaphragms                              |
| 2 Precision Ball Bearings    | 6 Inlet Valve Assembly                    |
| 3 Connecting Rods            | 7 Discharge Valve Assembly                |
| 4 Hydraulic Cells (Patented) | 8 C46 Pressure Regulating Valve (In-line) |

## Reliable, Efficient Pumping Action

The drive shaft (1) is supported in position by two precision ball bearings (2) positioned at either end of the shaft. Located between these bearings are either one or three cam shaft lobes with connecting rods (3) that are hardened, precision ground, and polished. Maintaining a high level of quality on the cam lobes and connecting rod surfaces ensures proper lubrication and reduced operating temperatures in the hydraulic end of the pump.

As the drive shaft turns, each cam actuates the attached connecting rod that is pinned into position at the end of each hydraulic piston. This action moves the piston forward and backward, converting the axial motion into linear pumping motion. The complete pumping mechanism is submerged in a lubricating oil bath.

Each piston contains a patented hydraulic cell (4) that is moved sequentially by the crank-shaft. The innovative and proprietary Hydra-Cell maintains the precise balance of oil behind the diaphragm (5) regardless of the operating conditions of the pump. The oil in Hydra-Cell is pressurized on the forward stroke of the piston causing the diaphragm to

flex, which drives the pumping action. The oil held in the Hydra-Cell balances the diaphragm against the liquid being pumped, maintaining no more than a 0.21 bar differential regardless of the pressure at which the liquid is being delivered - up to 172 bar on standard Hydra-Cell models and Hydra-Cell metering pumps.

Hydra-Cell crank-shaft pumps can have up to three diaphragms, and each diaphragm has its own pumping chamber that contains an inlet and discharge self-aligning, disk check valve assembly (6). As the diaphragms move back, liquid enters the pump through a common inlet and passes through one of the inlet check valves. On the forward stroke, the diaphragm forces the liquid out of the discharge check valve (7) and through the manifold common outlet. Equally spaced from one another, the diaphragms operate sequentially to provide consistent, low-pulse flow.

A Hydra-Cell C46 pressure regulating valve (8) is typically installed on the discharge side of the pump to regulate the pressure of downstream process or equipment.



# Hydra-Cell® Principles of Operation - Asynchronous Design

API 674 option available

## Exclusive Seal-less Diaphragm Design

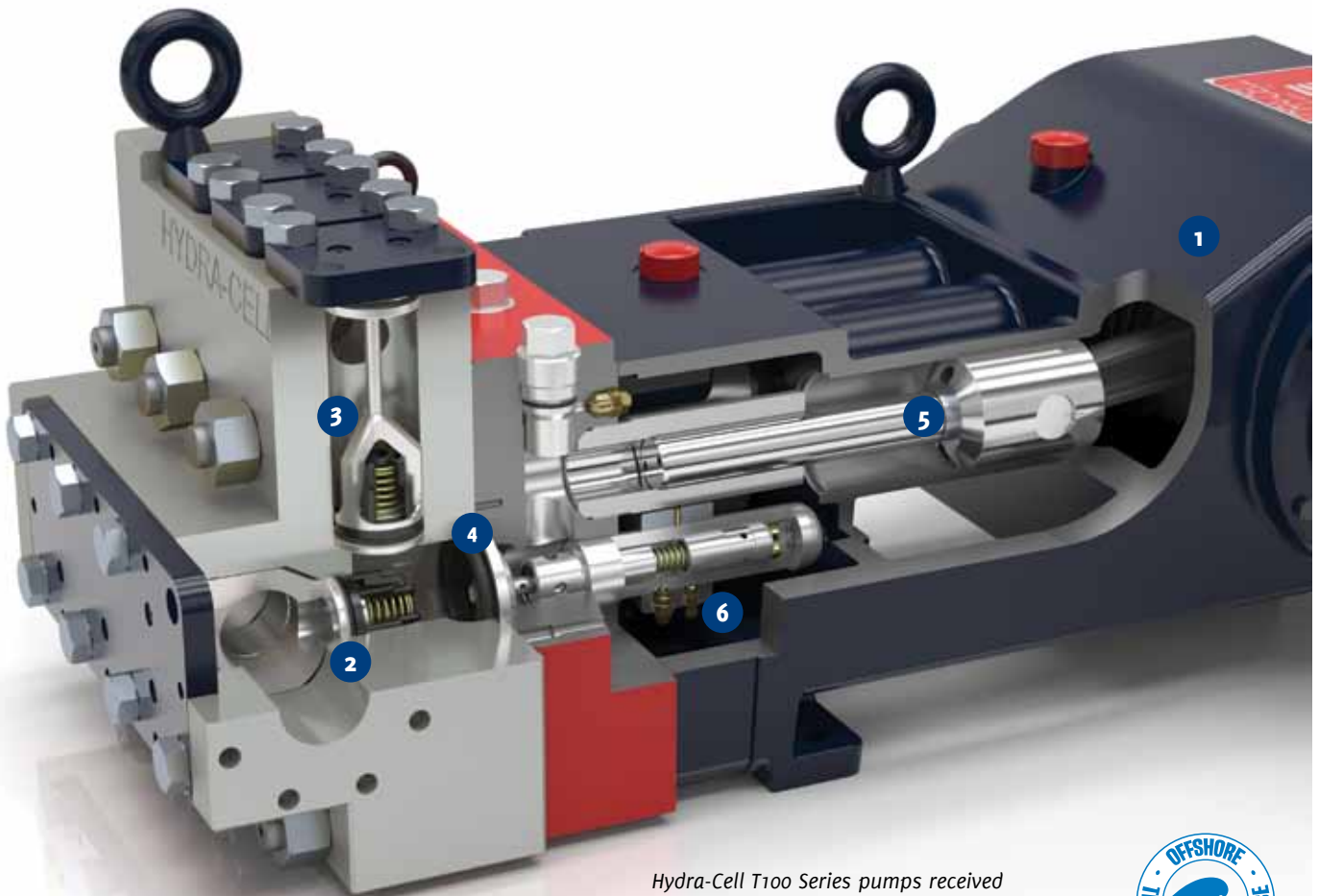

Hydra-Cell T100 Series pumps received a "Spotlight on New Technology" award from the Offshore Technology Conference.



## Asynchronous Models

- |                            |                                 |
|----------------------------|---------------------------------|
| 1 Drive Shaft              | 4 Diaphragms                    |
| 2 Inlet valve assembly     | 5 Plunger                       |
| 3 Discharge valve assembly | 6 Underfill and overfill valves |

## Reliable, Efficient Pumping Action

The seal-less design of Hydra-Cell High Horsepower pumps eliminates leaks, hazards and the expense associated with seals and packing. The diaphragms completely separate the process liquid from the pump drive with no dynamic seals or packing being exposed to the pumped liquid.

The pump's high efficiency results in lower energy costs than centrifugal pumps and other pump technologies, while the simple, asynchronous design and exceptionally rugged construction lead to very low maintenance and service requirements. The hydraulically balanced diaphragms are able to handle high pressures with low stress.

These pumps can operate with a closed or blocked suction line and can run dry indefinitely without damage, eliminating downtime and repair costs. Their low NPSH requirements allow for operation with a vacuum condition on the suction... positive suction pressure is not necessary.

Thanks to unique diaphragm and valve designs, these pumps are able to handle more abrasives with less wear than gear, screw or plunger pumps. Their compact design and double-ended shaft provide a variety of installation options.

Hydra-Cell High Horsepower pumps can be configured to meet API 674 standards – consult factory for details.

# Hydra-Cell®

## MATERIALS OF CONSTRUCTION

With over 40 years' experience in serving the metal cutting industry, including many world-class high pressure coolant manufacturers and the largest CNC machine tool manufacturers, Hydra-Cell pumps have proven performance in efficiently

pumping high pressure coolant and supporting customers globally. Hydra-Cell's unique multi-diaphragm, seal-less design reliably handles machine tool coolant with suspended metal particles, reduces costs and improves machining productivity.

### Manifolds

Manifolds for Hydra-Cell pumps are available in a variety of materials to suit your process application. They are easy to replace and interchangeable to accommodate different liquids processed by the same pump.



### Metallic Pump Heads

Metallic pump heads can handle higher operating pressures. Hastelloy CW12MW or Stainless Steel is also selected for corrosion resistance and other properties.

- Brass
- Bronze
- Cast Iron (Nickel-plated)
- Duplex Alloy 2205
- Super Duplex Alloy 2507
- Hastelloy CW12MW
- 304 Stainless Steel
- 316L Stainless Steel



### Diaphragms and O-rings

Diaphragms and corresponding o-rings are available in several elastomeric materials.

- Aflas (used with PTFE O-ring)
- Butyl
- Buna-N
- EPDM (requires EPDM-compatible oil)
- FFKM
- FKM
- Neoprene
- PTFE



## Valve Materials

Hydra-Cell valve assemblies (seats, valves, springs, and retainers) are available in a variety of materials to suit your process application.

### Valve Seats

- Ceramic
- Hastelloy CW12MW
- Nitronic 50
- Tungsten Carbide
- 17-4 PH Stainless Steel
- 316L Stainless Steel

### Valves

- Ceramic
- Hastelloy CW12MW
- Nitronic 50
- Tungsten Carbide
- 17-4 PH Stainless Steel

### Valve Springs

- Elgiloy (Exceeds SST grade 316L)
- Hastelloy CW12MW
- 17-7 PH Stainless Steel
- 316L Stainless Steel

### Valve Spring Retainers

- Celcon
- Hastelloy CW12MW
- Nylon (Zytel)
- Polypropylene
- PVDF
- 17-7 PH Stainless Steel

### Registered trademarks of materials:

Aflas®	Asahi Glass Co., Ltd.
Buna®-N (Nitrile)	E.I. Du Pont de Nemours and Company, Inc.
Celcon®	Celanese Company
Elgiloy®	Elgiloy Limited Partnership
Hastelloy® CW12MW	Haynes International, Inc.
Kynar® (PVDF)	Arkema, Inc.
Mesamoll®	Lanxess Deutschland GmbH
Neoprene®	E.I. Du Pont de Nemours and Company, Inc.
Nitronic® 50	AK Steel Corporation
Teflon® (PTFE)	E.I. Du Pont de Nemours and Company, Inc.
Viton® (FKM)	DuPont Performance Elastomers, LLC
Zytel® (Nylon)	E.I. Du Pont de Nemours and Company, Inc.



## Hydra-Cell G Series Seal-less Pumps



## Hydra-Cell T Series Seal-less Pumps



## Hydra-Cell Q Series Seal-less Pumps





# Hydra-Cell® Flow Capacities and Pressure Ratings

## G, T and Q Series Seal-less Pumps

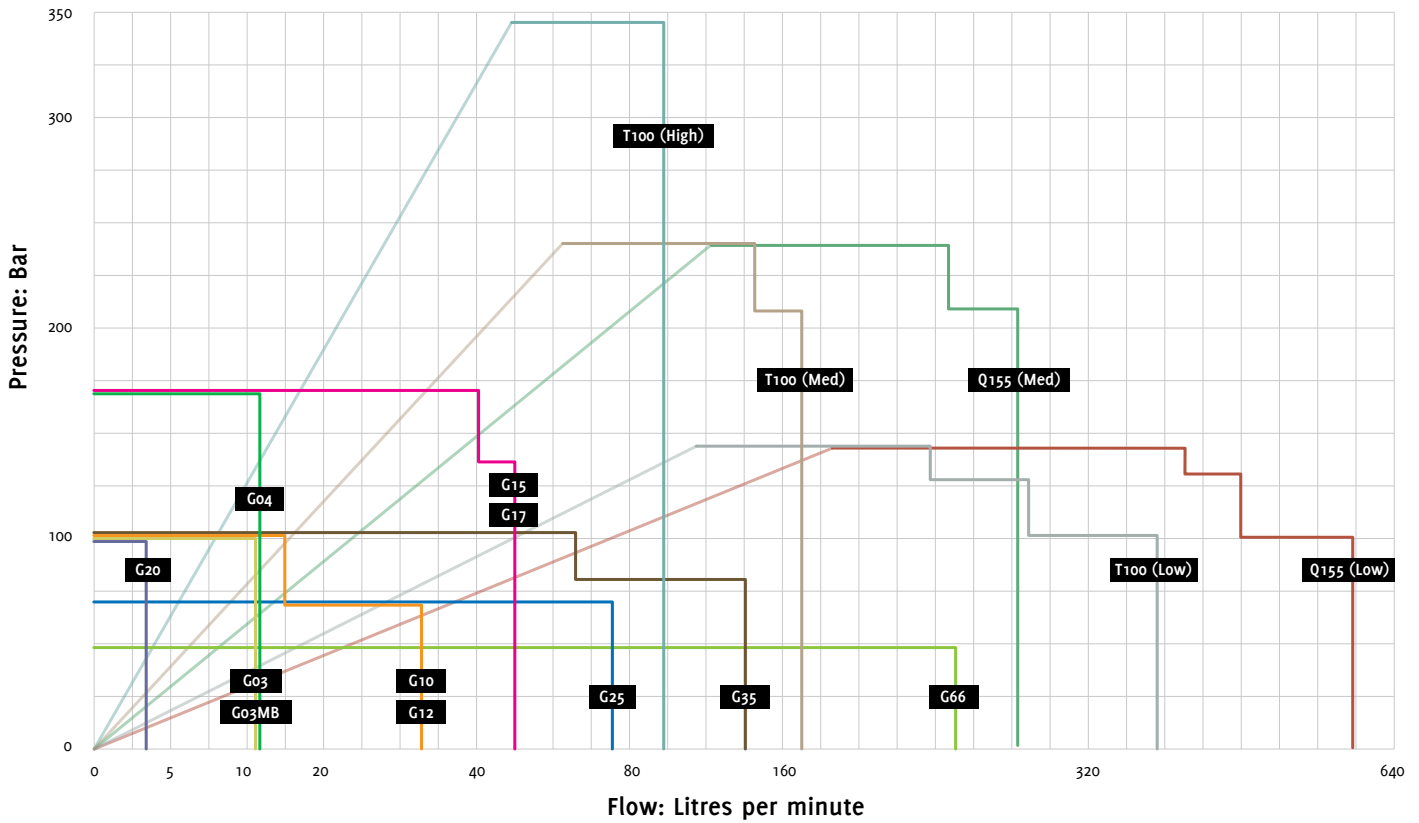

The graph above displays the maximum flow capacity at a given pressure for each model series. The table below lists the maximum flow capacity and maximum pressure capability of each model series.

Please note: Some models do not achieve maximum flow at maximum pressure. Refer to the individual model specifications in this section for precise flow and pressure capabilities by specific pump configuration.

Model	Maximum Capacity l/min	Maximum Discharge Pressure bar	Maximum Operating Temperature °C <sup>1</sup>	Maximum Inlet Pressure bar
G20	3.8	103	121°	17
G03	11.7	103	121°	17
G04	11.2	200	121°	34
G10	33.4	103	121°	17
G12	33.4	103	121°	17
G15/17	58.7	172	121°	34
G25	75.9	69	121°	17
G35	138	103	121°	34
G66	248	48	121°	17
T100S	98	345	82°	34
T100M	144	241	82°	34
T100K	170	207	82°	34
T100H	259	145	82°	34
T100F	290	128	82°	34
T100E	366	103	82°	34
Q155E	595	103	82°	34
Q155F	490	127	82°	34
Q155H	421	144	82°	34
Q155K	295	207	82°	34
Q155M	253	241	82°	34

Note Specifications are for metallic head pumps.

<sup>1</sup> Consult factory for correct component selection for temperatures from 160°F (71°C) to 250°F (121°C).

# Notes







**WANNER**  
*Hydra-Cell*<sup>®</sup>  
Partners in over 70 Countries

**WANNER ENGINEERING - WORLD HEADQUARTERS & MANUFACTURING**  
Minneapolis USA  
t: (612) 332-5681  
e: sales@wannereng.com

**WANNER ENGINEERING**  
Latin American Office  
t: +55 (11) 3565 4001  
e: sales@wannereng.com

**WANNER PUMPS**  
Shanghai CHINA  
t: +86-21-6876 3700  
e: sales@wannerpumps.com

**WANNER PUMPS**  
Kowloon HONG KONG  
t: +852 3428 6534  
e: sales@wannerpumps.com

**WANNER INTERNATIONAL**  
Hampshire UK  
t: +44 (0) 1252 816847  
e: sales@wannerint.com